



The world authority
in powered access

GUIDE TO NEW DESIGN, SAFE-USE AND TRAINING STANDARDS FOR MEWPS



CSA B354 – User's guide, February 2019. *Document version 2*

CURRENT STANDARDS

Standards are important and may establish standardized requirements for design of a product, process or system. They can specify performance of products or personnel. They can also define terms and definitions specific to the standard, so there is no misunderstanding among those using the standard.

The CSA B354 standards provide uniform guidance in the design and manufacturing of equipment. They also address the planning and operation for the safe-use of equipment and training requirements to aid users in achieving safe and effective use of the equipment. These standards assign responsibilities for various tasks to entities based on their roles as a manufacturer, dealer, owner, user, operator, and occupant. An individual or company may hold several roles; a user may also be an owner of a mobile elevating work platform (MEWP), resulting in responsibilities when acting in the role of an owner of the equipment and responsibilities of a user when as a user, authorizing employees to operate a MEWP.

Previously, CSA B354 standards requirements were specified by equipment classification: B354.1 for manually propelled platforms; B354.2 for scissor-type platforms and B354.4 for boom-type platforms. Each standard dictated requirements for design, safe-use and training to ensure the safe and effective use of each category of machine. These standards have been withdrawn.

NEW STANDARDS OVERVIEW

The new CAN/CSA B354 MEWP Design, Safe-use and Training suite of standards were recommended by the CSA B354 Technical Committee to be implemented by May 2018. The new standards are CSA B354.6: MEWP – Design, calculations, safety requirements and test methods; CSA B354.7: MEWP – Safety principles, inspection, maintenance and operation; and CSA B354.8: MEWP – Operator (driver) training.

The design standard specifies design calculations and stability criteria, construction, safety examinations and tests and is predominately intended for manufacturers; the safe-use standard specifies requirements for application, inspection, training, maintenance, repair and safe operation of equipment and is predominantly intended for owners, users, and operators; the training standard provides methods and guidelines to prepare MEWP training materials, defines administrative criteria and delivers elements required for proper training to implement the safe-use standard requirements and is predominantly intended for individuals or companies offering training.

The safe-use and training standards apply to both new and existing units and replace the inspections, maintenance, safe operating practices and operator training requirements of the CSA B354.1, B354.2 and B354.4 standards, which were withdrawn in 2018.

GENERAL CHANGES

- Terminology: Mobile Elevating Work Platforms, or MEWPs, will be the new universal term for this equipment, replacing Aerial Work Platform (AWP).
- The three new standards are written by primary task of design, safe-use and training to replace the three prior standards written by product type – manually propelled, self-propelled booms and scissors.
- New safe use and training requirements apply to new and existing MEWPs.
- The new training classifications are a combination of group and type. Group a and b are defined by the possible configuration of the MEWP, determined by the center of the platform in relation to the tipping line. If the platform is always inside the tipping line then it is Group a (for example scissor lift, vertical lift) and if the platform can be positioned beyond the tipping line then it is Group b (for example boom-lift). Types 1, 2 and 3 define travelling, with 1 not able to travel out of stowed position, 2 being where travel is controlled from the chassis and 3 able to travel when elevated:

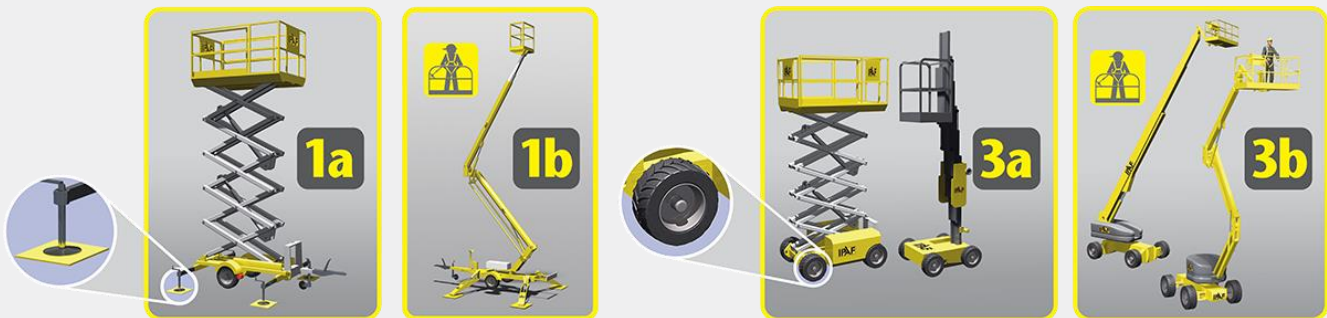

DESIGN (MANUFACTURE) CHANGES

This section identifies some typical outcomes that will impact users:

- Platform load-sensing: Most machines will monitor load and will not operate with normal control functionality when overloaded beyond rated capacity, except emergency controls.
- New wind force requirements: Maximum wind rating must be listed at the control position. There is potential for reduced capacity on scissors and vertical platform lifts. MEWPs can be designed for indoor use only with zero exposure to wind.
- New stability test requirements: Results in foam-filled only (no air-filled) tires on the majority of rough-terrain scissors or booms
- Chain entrances on scissors and vertical platform lifts are no longer allowed. Toe boards will now be required at entrances on all MEWPs.
- In addition to the existing required alarm for tilt sensor, MEWPs will be prevented from certain movements when reaching allowed limits of chassis inclination.
- A decal or other means must be provided on the MEWP to mark the date of the last annual inspection and the date of the next future inspection.



- The operator's manual shall include a listing of MEWP functions, features, operating characteristics, limitations and devices to be included in familiarization, making it clear what must be included.
- Minimum railing heights increased from 0.99 m (39 in) to 1.1m (43.3 in), which may require folding rails for movement through standard doorways on some models.

SAFE-USE CHANGES

- Safe-use planning requires a plan specific to MEWPs to be developed by users to include tasks such as a risk assessment, the selection of the proper MEWP for application, and access, preparation and maintenance of the work site prior to using the MEWP.
- The user is required to provide periodic "on-the-job" operator evaluations to ensure conformance with this Standard
- Examples when retraining is required are provided.
- There is a new user responsibility to ensure the operator of a MEWP is medically and physically fit to operate the MEWP safely.
- Requirements for modifications have been expanded to include more details concerning record keeping and communication (labels, instructions, serial plates). Modifications must only be performed if approved by the manufacturer or their successor, or, if they are no longer in business or it is not possible to obtain a response, an engineer.
- Another new requirement is performing a risk assessment to include identification of task to be undertaken, selection of appropriate MEWP, assessing risk, developing control measures, and identifying safe work procedures. It is important to recognize that this is required for all MEWP operations.
- Included in a risk assessment is the user requirement to develop a rescue plan for workers who may require rescue from a platform in elevated position. This includes prior planning to ensure a safe and timely rescue. This must address rescues caused by MEWP malfunction and falls from the work platform.
- Detailed guidance and requirements are provided for specific requirements of operation such as wind, storm and ground condition consideration, ventilation, and transporting and travelling on public roads etc.
- The requirement that exiting a MEWP at height is only permitted through a procedure provided by the manufacturer, or in their absence, an engineer, whose procedures must address requirements defined in the standard. If the risk assessment determines that exiting at height is the safest method of work, then this procedure shall be followed when the exit at height is conducted.
- Electrical hazard avoidance offers expanded guidance including specific minimum safe approach distance (MSAD) requirements and the requirement to consider conductors to be energized and not insulated unless determined otherwise.
- The employer or user has the ultimate responsibility to ensure operators are trained and familiarized as defined in the standard prior to authorization to operate a MEWP. Dealers and owners must offer appropriate training and familiarization.
- The user shall ensure prior to each operation that the MEWP operator provides instruction or otherwise ensure that all occupants have a basic level of knowledge to work safely using the MEWP.

TRAINING CHANGES

- Prior training that is compliant with previous standards will require supplemental training to address the new requirements.
- Operator training is required for each MEWP classification.
- The user shall ensure that training is presented in a language that trainees can understand.



- All training must comply with administration of training defined in the training standard to include training content, trainer qualification, training environment, testing, and documentation.
- Training theory may be delivered by either a qualified trainer or through an online or electronic medium. In either case, a practical evaluation must follow the theory training.

BECOMING COMPLIANT THROUGH IPAF TRAINING

The best way to ensure compliance is for operators to hold a PAL Card and supervisors to complete IPAF's MEWPs for Managers course. Utilizing the latest generation of online learning tools, IPAF offers operator trainees the option of completing the theory requirement of their training via interactive eLearning. The benefits of eLearning include:

- Trainees complete the module online – anytime, anywhere, on any device and at their own pace;
- Trainees can then complete the supervised hands-on practical test and evaluation at an approved training center to complete operator training;
- Operators don't have to take so much time away from the job to complete training;
- In most cases necessary a hands-on practical test can be concluded comfortably inside a few hours;
- Trainees opting for an instructor-led theory course also benefit from sessions enhanced by the interactive material in the online module;
- Available in English or French.

In addition, IPAF's MEWPs for Managers course fulfils the requirement for MEWP supervisor training. For more information, please visit www.ipaf.org/en-us/m4m

FURTHER INFORMATION AND SUPPORT

This document is intended to raise awareness of the **key changes only** in the new standards; IPAF strongly recommends that you read the full version of the new standards to ensure all responsibilities are addressed.

For further information about the new North American MEWP standards, advice about how to become compliant and membership or training support enquiries, email USA@ipaf.org or visit www.ipaf.org/contact for details of how to get in touch with your nearest IPAF office or representative.