



**INTERNATIONAL POWERED
ACCESS FEDERATION**





IPAF ANCH'10





www.ipaf.org



Le MEWP Elettriche

Paolo Pianigiani

Bologna, 24 Maggio 2018
Savoia Regency

La prima domanda di un'Azienda che si pone verso il mercato è di cercare di capire il contesto e le evoluzioni del mercato ed i suoi trend principali

Riusciamo a vedere il futuro ?



Le MEWP Elettriche



www.ipaf.org

- Economia Circolare
- Green Economy
- Industria 4,0



IPAF
ANCH'10

Il mondo Automotive

- **Rivoluzione Volvo: dal 2019 produrrà solo auto elettriche e ibride**
- Secondo l'**internatonal Energy Agency**, entro il **2030** il mercato delle auto elettriche coprirà il **26% del totale** parco circolante

Formula «E»



Ed il mondo delle costruzioni e logistica ?



Intermat 2018

- **Mecalac spazio all'elettrico**
Il nuovo escavatore gommato **e12** è **100% elettrico**
- **Wacker Neuson a Intermat 2018** presenterà la sua **prima piastra vibrante ad alimentazione elettrica a batteria**; la **AP1850e**
- **Arriva il mini elettrico di JCB**
Il nuovo miniescavatore elettrico **JCB 19C-1 E-TEC**

Le MEWP Elettriche



www.ipaf.org

Nella progettazione e realizzazione di macchine è fondamentale, nel rispetto dell'ambito normativo, tenere sempre fermo un concetto :



- **«Sicurezza ed Ergonomia»**



- **«Professionalità»**



- **«Attenzione all'ambiente»**



- **La gamma dei nuovi modelli «IM»**
 - I «driver» del rinnovamento di prodotto
 - ✓ Innovazione chiave di svolta per la ripresa



La gamma dei nuovi modelli «IM»

- I «driver» del rinnovamento di prodotto
 - Nessuna Limitazione nell'operatività
 - Riduzione dei pesi
 - Incremento delle portate
 - Facilita di utilizzo e manutenzione

La gamma dei nuovi modelli «IM»

Il progetto

Elettriche per utilizzo interno ed esterno

Le MEWP Elettriche



www.ipaf.org

La gamma dei nuovi modelli «IM»

Nuovo design del carro
per migliorare il
baricentro e stabilità
operativa

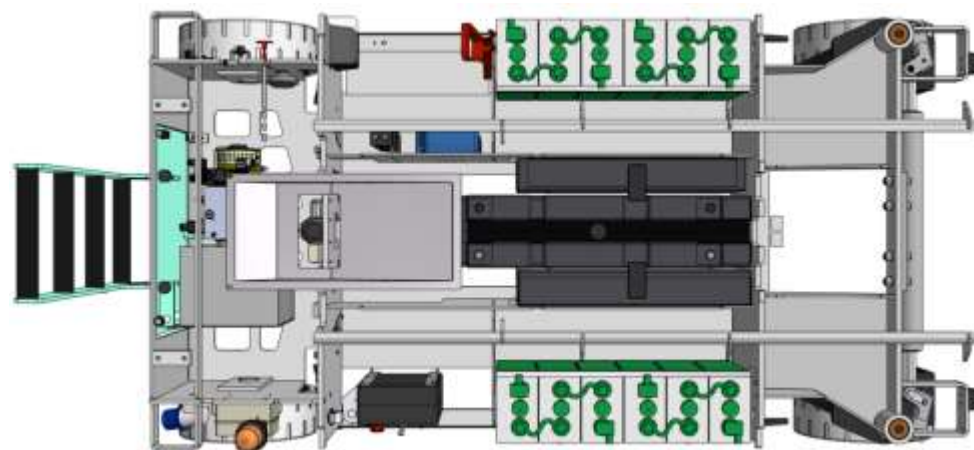
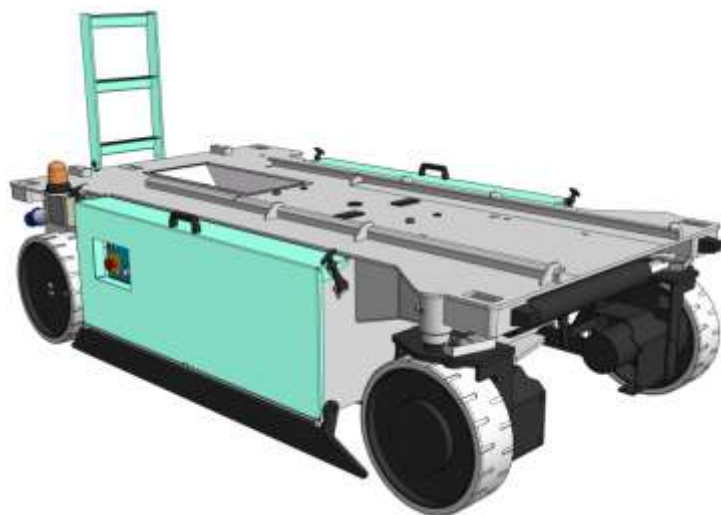

Ottimizzazione e razionalizzazione
della disposizione dei componenti
del carro



Le MEWP Elettriche



www.ipaf.org

La gamma dei nuovi modelli «IM»

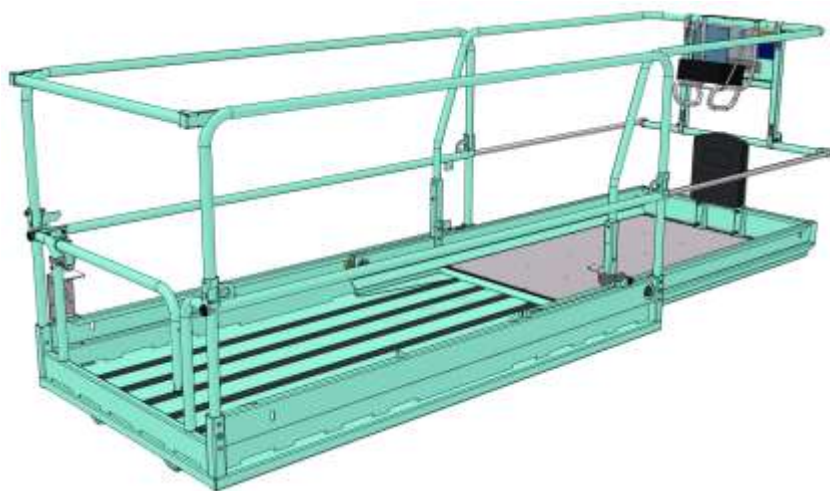

Nuovo design del sistema di abbattimento della protezione piattaforma

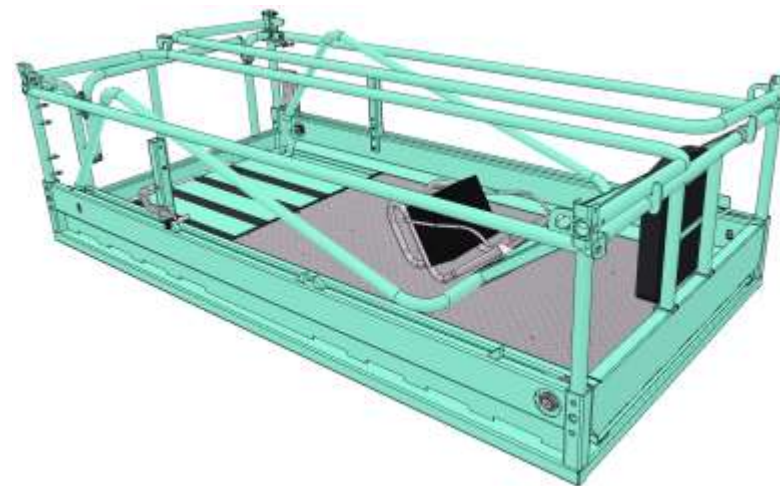

- Estensione 1300 mm.
- Nuovo design porta di accesso

IPAF
ANCH'IO

La gamma dei nuovi modelli «IM»

Il progetto

PLE 4X4 Elettriche e Bienergia per utilizzo esterno ed interno

Le MEWP Elettriche



www.ipaf.org

La gamma dei nuovi modelli «IM»

Allestimento alimentazione Elettrica _ Batterie

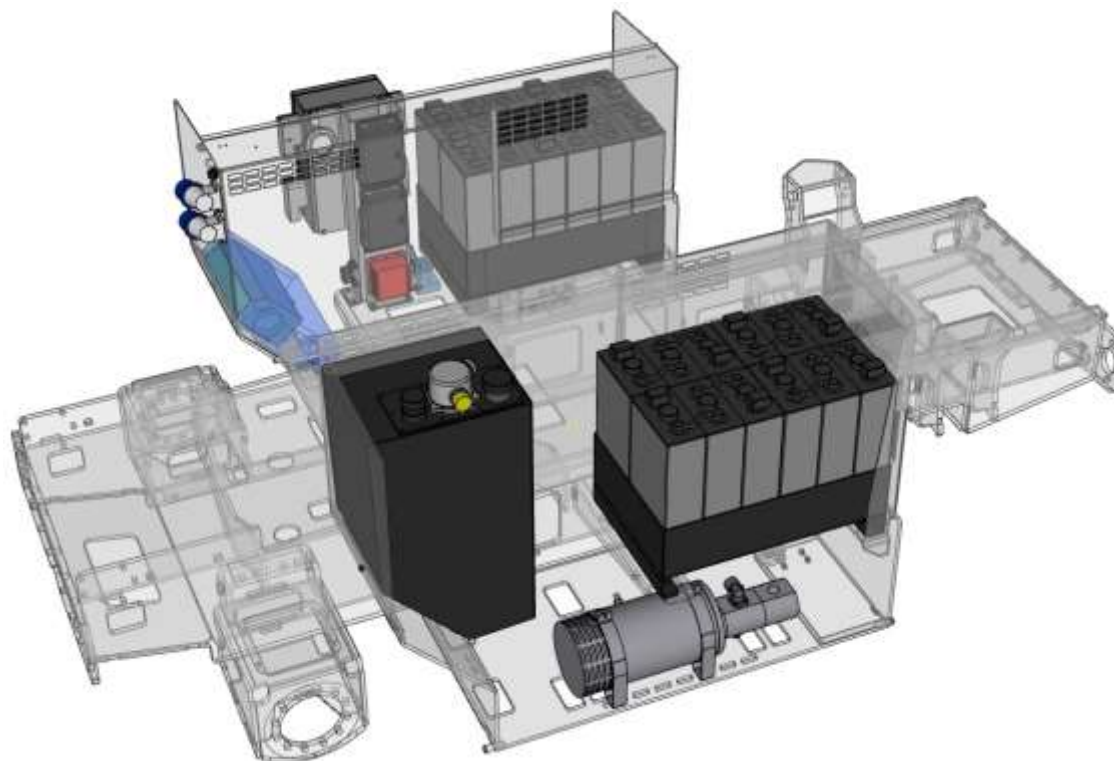

IPAF
ANCH'10

MEWP Elettriche



www.ipaf.org

La gamma dei nuovi modelli «IM»

Allestimento alimentazione Bi energia Diesel Elettrica AC a Batterie

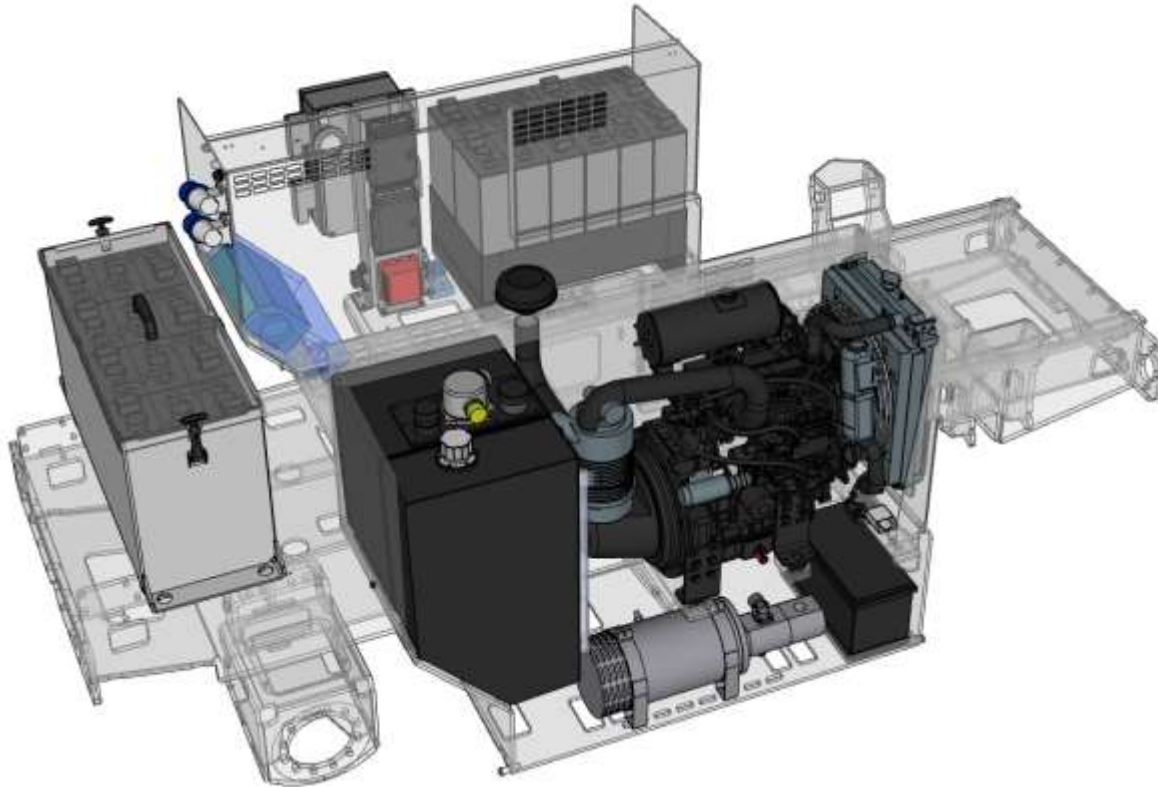

IPAF
ANCH'10

La gamma dei nuovi modelli «IM»

Assale Oscillante e Zavorre

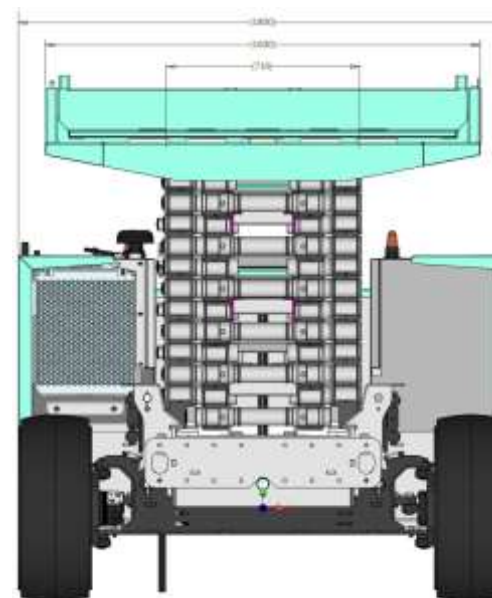
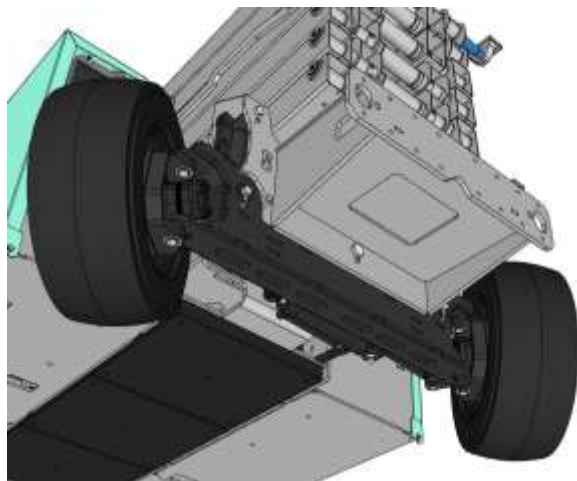

Nuova forbice di sollevamento

Nuovo dimensionamento in larghezza per una maggiore stabilità in utilizzo

MEWP Elettriche



www.ipaf.org

La gamma dei nuovi modelli «IM»

Stabilizzazione:

Allestibile con o senza Stabilizzatori

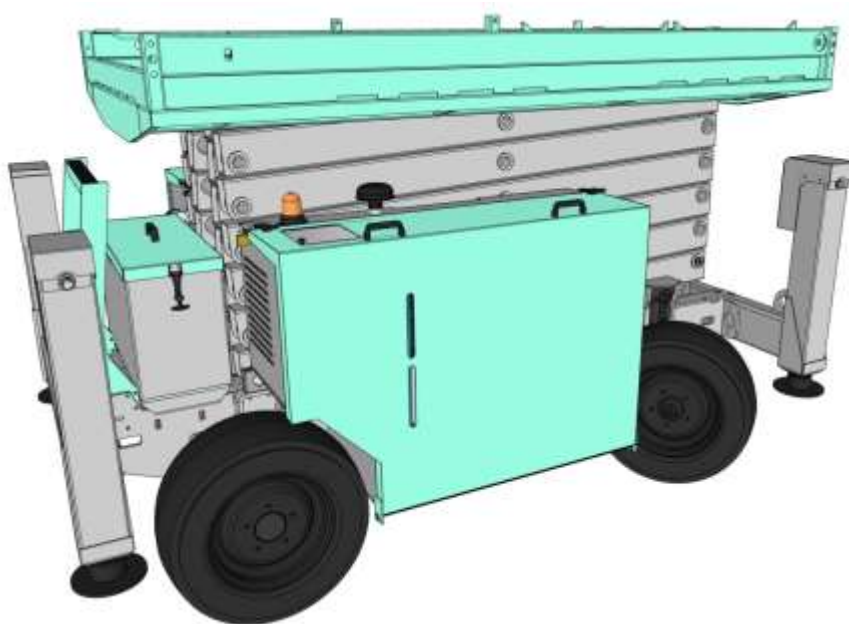

IPAF
ANCH'10

La gamma dei nuovi modelli «IM»

I modelli

Le MEWP Elettriche



www.ipaf.org

La gamma dei nuovi modelli «IM»

IM 4680 MC
IM 5980 MC

IM 4680
IM 5980
IM 7380

IM 6390
IM 8290
IM 10090
IM 12090

IM 8122
IM 10122
IM 12122
IM 14122



IPAF
ANCH'10

Le MEWP Elettriche



www.ipaf.org

La gamma dei nuovi modelli «IM»

IM 13180



IM 11180



IPAF
ANCH'10

Una delle massime di un leader leggendario dell'industria

**“If you don't have a
competitive advantage,
don't compete.”**

JACK WELCH
legendary CEO



GRAZIE

